



PRAKASH

Worldwide

Quality, Reliability, Life



SEWAGE PUMP



Sewage Pump

Applications

- Municipal Project
- Industrial building
- Mining
- Civil engineering

Specifications

- Water temperature : up to 35°C
- PH : 6.5 to 8.5
- Density of liquid : 1.3g/cm³
- Power : 0.75 to 7.5Kw
- Insulation Class: F
- Protection Class : IP 68
- Capacity : Up to 175 m³ /h
- Head : Up to 43m
- Power Supply : single phase 220V ±10%,50 Hz ; three phase 380V ± 10%,50Hz
- Maximum immersion depth : 10m
- Cable : Length 8mtr

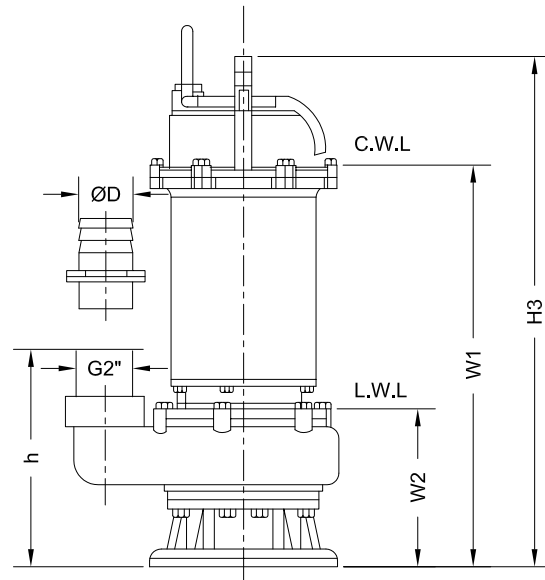
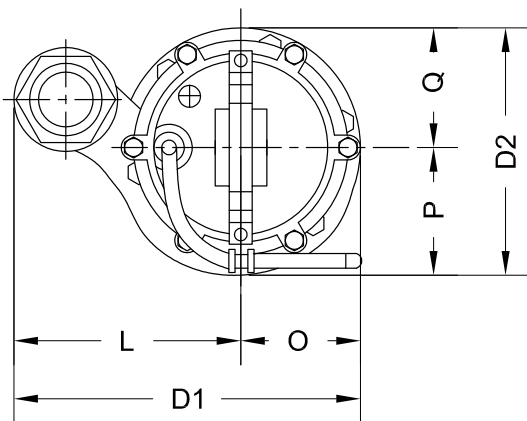

W1 : Continue running water level
W2 : Lowest running water level

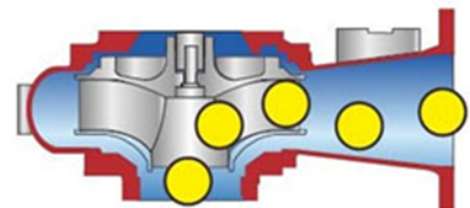

Allowed by the particle diameter

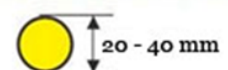

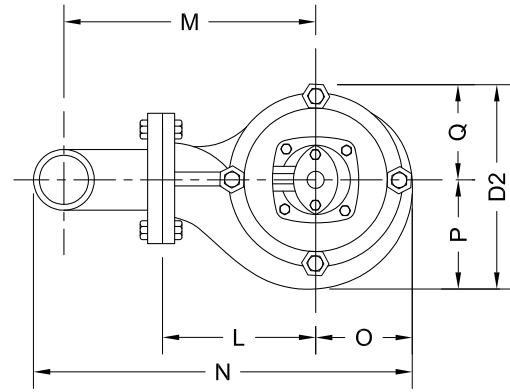
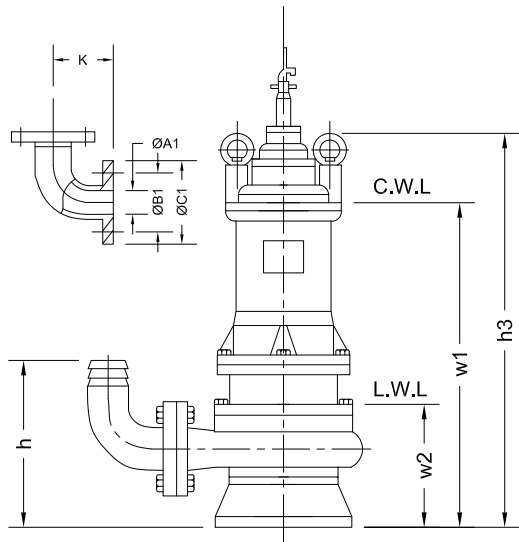

W1 : Continue running water level
W2 : Lowest running water level

Model	Power		Voltage	Outlet Inch	Guide Rial	Rated Capacity	Rated Head	Impeller Passage	N.W (Kg)
	KW	HP							
PSP15-15-1.5	1.5	2	380	2.5	50-65	15	15	25	25
PSP25-17-2.2	2.2	3		2.5	65-65	25	17	25	44
PSP40-9-2.2	2.2	3		3	65-80	40	9	30	45
PSP15-26-3	3	4		2	50-50	15	26	25	50
PSP25-22-3	3	4		2.5	65-65	25	22	30	50
PSP40-13-3	3	4		3	80-80	40	13	30	52
PSP40-18-4	4	5.5		3	80-80	40	18	30	65
PSP60-13-4	4	5.5		4	80-100	60	13	30	65
PSP15-40-5.5	5.5	7.5		2	50-50	15	40	20	73
PSP30-30-5.5	5.5	7.5		3	80-80	30	30	30	75
PSP45-22-7.5	7.5	10		4	100-100A	45	22	30	123
PSP100-10-7.5	7.5	10		6	150-150	100	10	40	123

Model	Power		Outlet	Q	US GPM																		
	KW	HP			M ³ /H	0	22	44	66	88	110	132	154	176	198	220	242	264	286	308	330	352	
						LPM	0	83	167	250	333	417	500	583	667	750	834	917	1000	1084	1167	1250	1334
PSP15-15-1.5	1.5	2	2.5	H (m)	20	18.5	17.5	16	15	13	11.5	9.5											
PSP25-17-2.2	2.2	3	2.5		25	23	22	20.5	19.0	17	15	12.5	10										
PSP40-9-2.2	2.2	3	3		16	15.5	14.5	13.5	12.5	11.5	11	10	8.5	7	6	5	4	2.5					
PSP15-26-3	3	4	2		29	28	27.5	26	24.5	22.5	21	19	17.5	15.5	14								
PSP25-22-3	3	4	2.5		27.5	26	25	24.0	22.5	21	19	17.0	15	12.5	10								
PSP40-13-3	3	4	3		21	19.5	18.5	17	15.5	14	13	12	11	10	9	8	7	5.5	4				
PSP40-18-4	4	5.5	3.0		23	23	22.5	22	21	20	19.5	18	17	16	15	13.5	12	10.5	9	7.5			
PSP60-13-4	4	5.5	4.0		23	22.5	22	21.5	20.5	19.5	18.5	18	17	16	15	14	12.5	10.5	9	7.5	6		
PSP15-40-5.5	5.5	7.5	2.0		43	42.5	41	39.5	38	36.5	34.5	32.5	30.5	28	25								
PSP30-30-5.5	5.5	7.5	3.0		35	34	33.5	33	32.5	31.5	30	28	25	22	16	4							
PSP45-22-7.5	7.5	10	4		28	27.5	27	26.5	26	25	24	23.5	22.5	21.5	20.5	19	18	16	14	10.5			

Model	Power		Outlet	Q	US GPM								
	KW	HP			M ³ /H	0	110	220	330	440	550	661	771
						LPM	0	417	834	1250	1667	2084	2501
PSP100-10-7.5	7.5	10	6	H (m)	15.5	15	14	12	10	8	6.5	5	

Model	Dimensions In mm														
	φ D	h	W1	W2	H3	L	O	Q	P	D1	D2				
PSP15-15-1.5	65	201	373	142	486	166	85	89	83	251	172				

Model	Dimensions In mm																
	φ D	φ A1	φ B1	φ C1	φ d1	h	W1	W2	H3	K	N	O	P	Q	L	M	D2
PSP25-17-2.2	65	65	130	160	4-φ14	223	445	150	550	122	365	105	115	100	165	228	215
PSP40-9-2.2	85	65	130	160	4-φ14	251	455	158	560	122	385	105	112	96	160	245	208
PSP15-26-3	50	50	110	140	4-φ14	212	464	150	570	100	360	105	115	97	165	230	212
PSP25-22-3	65	65	130	160	4-φ14	222	464	150	570	122	365	105	115	98	165	228	213
PSP40-13-3	80	80	150	190	4-φ14	262	490	177	595	140	380	105	115	98	155	235	213
PSP40-18-4	80	80	150	190	4-φ14	272	528	195	640	140	375	105	112	98	150	230	210
PSP60-13-4	100	80	150	190	4-φ14	302	528	195	640	150	405	105	112	98	150	250	210
PSP15-40-5.5	50	50	110	140	4-φ14	237	523	165	645	100	390	120	125	115	180	245	240
PSP30-30-5.5	80	80	150	190	4-φ14	270	540	182	660	140	405	110	115	105	175	255	220
PSP45-22-7.5	100	100	170	210	4-φ14	340	660	265	820	150	495	140	150	130	205	305	280
PSP100-10-7.5	150	150	225	26	8-φ14	560	670	280	830	230	565	145	160	135	210	345	295

Hydraulic Performance Curve

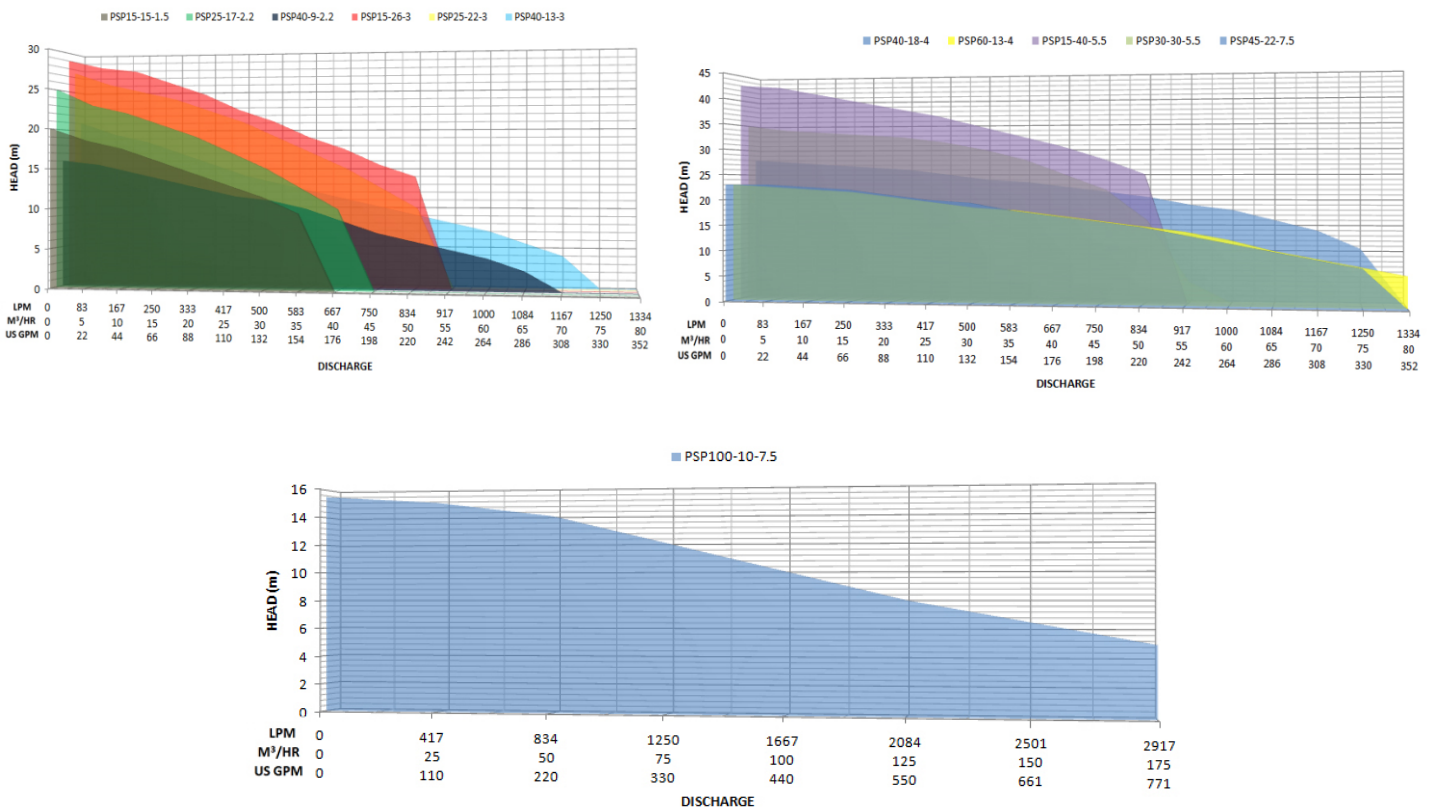

Sewage Pump Guide Rail System Details

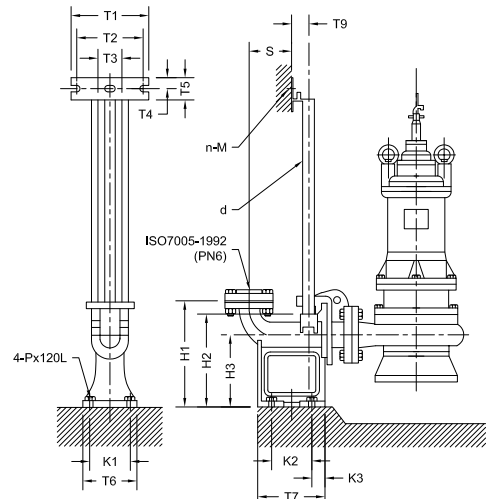

MODEL	T1	T2	T3	T4	T5	T6	T7	T8	T9	K1	K2	K3	S	H1	H2	H3	D	n-M	P	A
50-50	288	185	70	25	63	160	200	10	50	120	120	40	125	250	203	170	25	2-M10x40	M16	φ110/4-φ14
50-65	288	185	70	25	63	160	200	10	50	120	120	40	125	250	203	170	25	2-M 10x40	M16	φ110/4-φ14
65-65	288	195	80	25	63	190	220	10	60	120	120	40	130	250	203	175	32	2-M10x40	M16	φ130/4-φ14
65-80	288	195	80	25	63	190	220	10	60	120	120	40	130	270	220	175	32	2-M10x40	M16	φ130/4-φ14
80-80	288	195	80	25	63	220	250	15	60	170	170	40	165	290	242	192	32	2-M10x40	M16	φ150/4-φ18
80-100	288	195	80	25	63	220	250	15	60	170	170	40	165	290	242	192	32	2-M10x40	M16	φ150/4-φ18
100-100A	362	245	100	30	71	250	290	19	95	200	200	45	181	340	285	220	32	2-M 12x40	M16	φ170/4-φ18
100-100	410	315	170	30	60	320	385	17	90	260	300	48	200	305	245	200	32	2-M12x50	M18	φ170/4-φ18
150-150	410	260	280	30	60	400	410	90	100	300	300	55	300	480	388	300	40	2-M12xS0	M20	φ225/8-φ18

Manhole Sewage Application

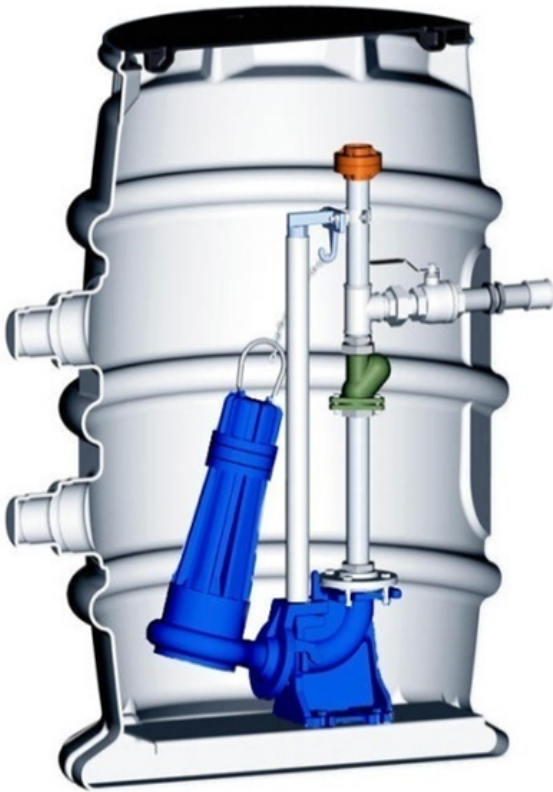

Waste Water Treatment From Building Basement



PRAKASH

Worldwide

Prakash Pump

Naroda Road, Ahmedabad-380025. Gujarat, India

Phone : +919925249371 | Email:info@prakashpump.com | www.prakashpump.com

UAE : 00971 50 6731283 | 00971 37222733

Oman : 00968 95690021 | 00968 26883982



Scan QR Code to Get
Quotation by Email



Scan QR Code to Get
Quotation by SMS



Scan QR Code to
Download e-Catalogue

